



ROLLING STACK
HIGH DENSITY ROLLING STOCK CRATES



ROLLING STACK

HIGH DENSITY ROLLING STOCK CRATES



DURABLE

Designed tough for demanding workplace environments.



MOVEABLE

Compatible with all major forklift manufacturers and types.



REPAIRABLE

Impact damage, dents & scrapes can all be repaired on 100% of BANAIR equipment.



LIFETIME WARRANTY

Protecting your investment with our stamp of quality



SPACE SAVING

Optimize your available warehouse cube: eliminate stored air.



- VARIOUS INTERNAL CRATE SIZES FOR A RANGE OF ROLLING STOCK
- MULTIPLE TIE DOWN POINTS FOR TO SUIT VARIOUS SIZED ROLLING STOCK
- 5K,8K,10K CAPACITY CRATES
- DETACHABLE RAMP PANELS
- ISO CORNER CASTORS
- PAINTED FINISH
- OPTIONAL DETACHABLE WINCH (SECURED BY SAFETY HOOKS)
- CUSTOM STEEL LUGS ENGAGE WITH THE FOUR BOTTOM ISO CORNER CASTINGS
- REMOVABLE BRACING ALLOWING FOR TALLER ITEMS
- SUITABLE FOR USE WITH STANDARD ALL-TERRAIN FORKLIFTS

**ROLLING
STACK**



ROLLING STACK

INTERGRATE WITH MOBILE BASES TO FURTHER MAXIMISE WAREHOUSE SPACE





ROLLINGSTACK SIZES:
(L).(W).(H) Inches - capacity

RS170.88.52-8K

RS170.88.84-8K

RS170.110.110-8K

RS196.110.110-8K

RS240.96.104-5K

RS134.75.68-3K

RS240.96.104-12K

RS207.88.52-12K

**ROLLING
STACK**

ROLLINGSTACK

SUITABLE FOR

- TANK,FABRIC,COLLAPS 10K
- LINER, BERM TANK 10K
- TANK,FABRIC,COLLAPS 210K
- LINER,BERM,TANK,FAB 210K
- TANK,FABRIC,COLLAPS 3K
- TANK,FABRIC,COLLAPS 50K
- PUMPING ASSEMBLY,FL (PMU-27)

BOMBLIFT FAMILY e.g:

- MJ-1 BOMB LIFT TRUCK
- MHU83 BOMB LIFT*
- MHU83D/E BOMB LIFT* (with small overhang on crate)



MULTIPLE TIE DOWN POINTS FOR VARIOUS SIZED ROLLING STOCK

MULTIPLE TIE DOWN POINTS FOR VARIOUS SIZED ROLLING STOCK

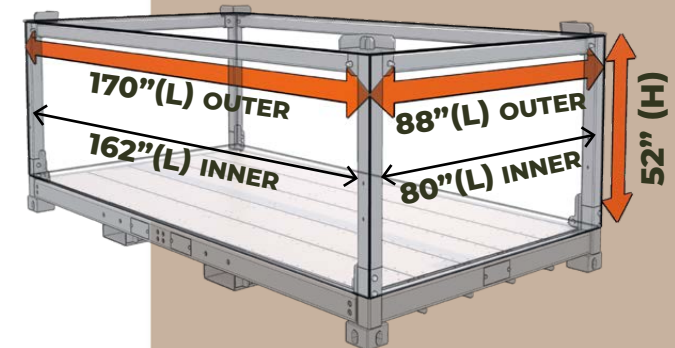

RS170.88.52-8K
COMPATIBLE WITH RS170.88.84-8K

BAN AIR

© 2021 Elements Industrial Storage Ltd. All rights reserved.
No unauthorized copying or distribution without prior permission

ROLLINGSTACK

SUITABLE FOR

DABS assets e.g:

- Light kits/carts/towers
- Wheeled generators (AMMPS-1070/1060)
- Potable water tanks
- Switching units
- Hydraulic pump units
- R22 pump

LIGHTWEIGHT TACTICAL VEHICLES e.g:

- POLARIS MV850
- POLARIS MRZR
- POLARIS MRZR D4
- POLARIS RANGER CREW



CUSTOM STEEL LUGS ENGAGE WITH THE FOUR BOTTOM ISO CORNER CASTINGS

MULTIPLE TIE DOWN POINTS FOR VARIOUS SIZED ROLLING STOCK

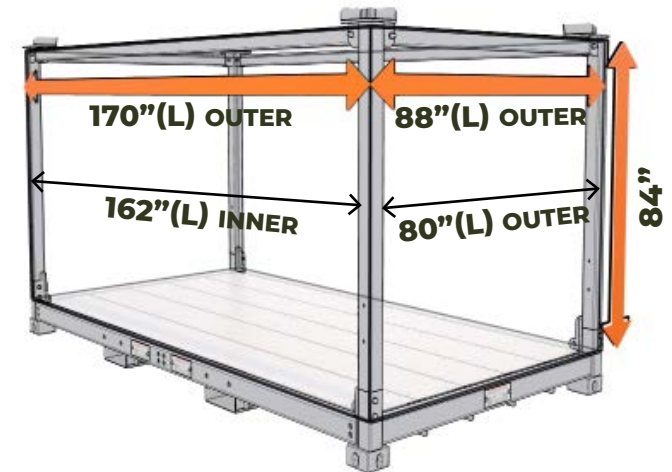

RS170.88.84-8K
COMPATIBLE WITH RS170.88.52-8K

BAN AIR

© 2021 Elements Industrial Storage Ltd. All rights reserved.
No unauthorized copying or distribution without prior permission

ROLLINGSTACK

SUITABLE FOR

- 500 Gal LOX Tank
- ABFDS
- TASS

CUSTOM STEEL LUGS ENGAGE WITH THE FOUR BOTTOM ISO CORNER CASTINGS

MULTIPLE TIE DOWN POINTS FOR VARIOUS SIZED ROLLING STOCK

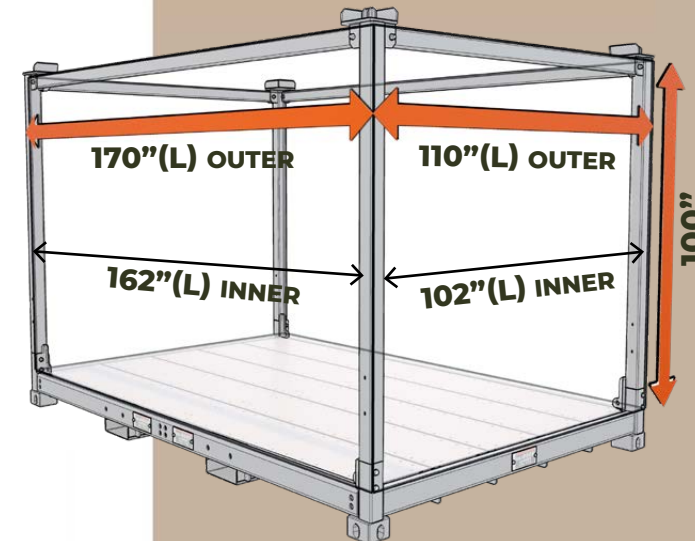

RS170.110.110-10K

BAN AIR

© 2021 Elements Industrial Storage Ltd. All rights reserved.
No unauthorized copying or distribution without prior permission

ROLLINGSTACK

SUITABLE FOR

- R-18 PUMPING ASSEMBLY,FL
- R-19 FILTER-SEPARATOR,LI
- R-20 SERVICING PLATFORM

CUSTOM STEEL LUGS ENGAGE WITH THE FOUR BOTTOM ISO CORNER CASTINGS

MULTIPLE TIE DOWN POINTS FOR VARIOUS SIZED ROLLING STOCK

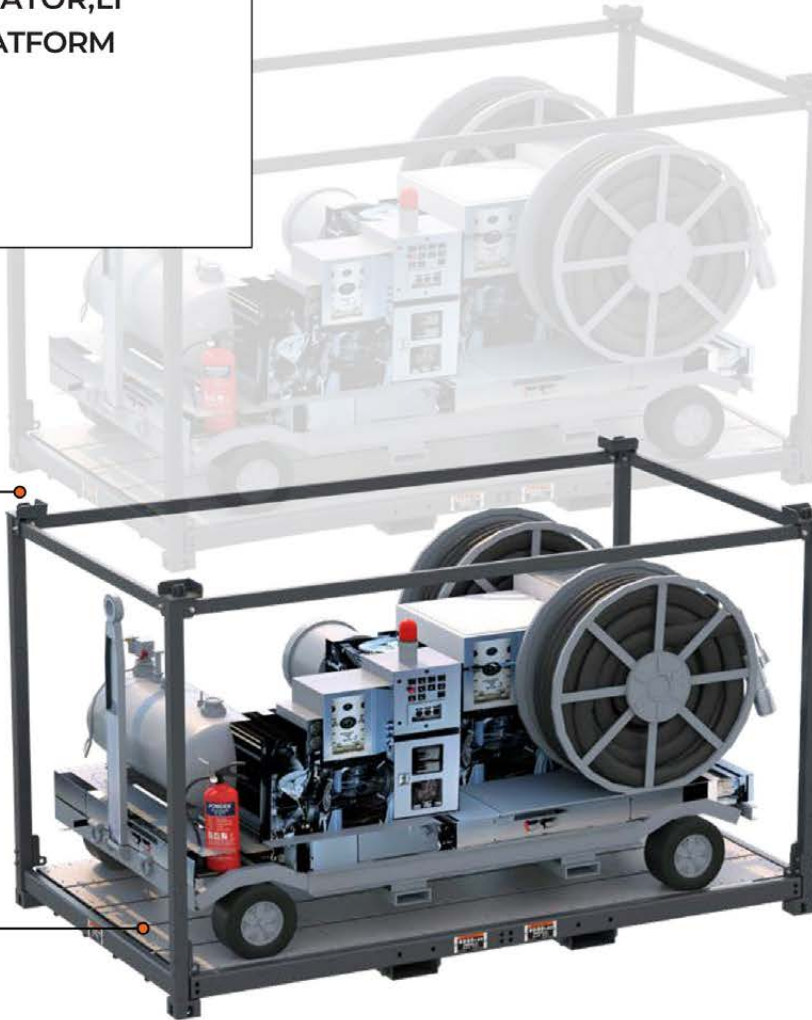

- 1. FILTER-SEPARATOR,LI (R19)**
60"(W) x 144"(L) x 73"(H)
3200lbs
- 2. PUMPING ASSEMBLY,FL (R18)**
60"(W) x 148"(L) x 97"(H)
4750lbs
- 3. SERVICING PLATFORM (R20)**
95"(W) x 138"(L) x 91"(H)
4600lbs

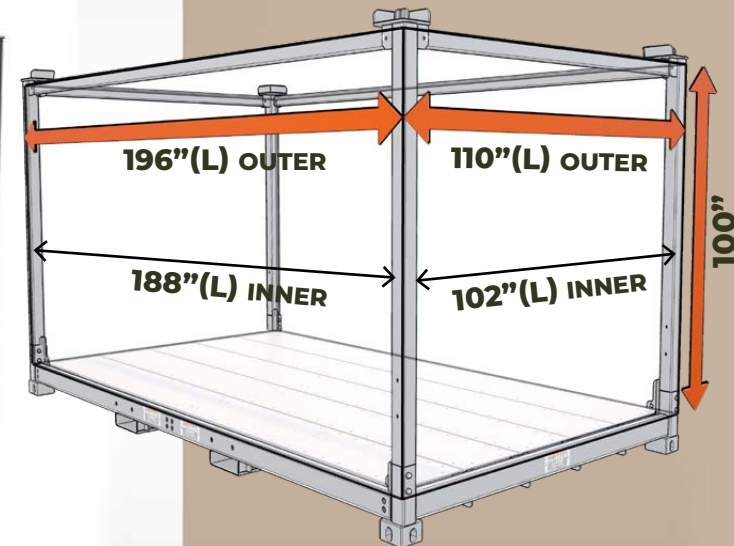

RS196.110.110-8K

BAN AIR

© 2021 Elements Industrial Storage Ltd. All rights reserved.
No unauthorized copying or distribution without prior permission

ROLLINGSTACK

SUITABLE FOR

- Oshkosh - PLOUGH
- Oshkosh - BRUSH

CUSTOM STEEL LUGS ENGAGE WITH THE FOUR BOTTOM ISO CORNER CASTINGS

HIGH LEVEL TIE DOWN RESTRAINTS

MULTIPLE TIE DOWN POINTS

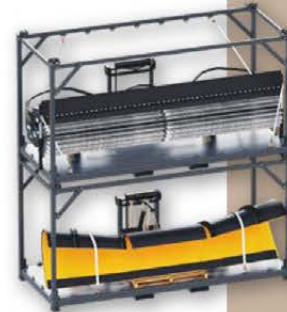

1. OSHKOSH - BRUSH
70"(W) x 244"(L) x 102"(H)

2. OSHKOSH - PLOUGH
94"(W) x 240"(L) x 52"(H)



20FT ISO CASTING POSITIONS ON THE BOTTOM ALLOW CRATES TO BE STACKED ON 20FT CONTAINERS

RS240.96.104.5K

 BANAIR

© 2021 Elements Industrial Storage Ltd. All rights reserved.
No unauthorized copying or distribution without prior permission

ROLLINGSTACK

SUITABLE FOR

- Variety of Snow Machines

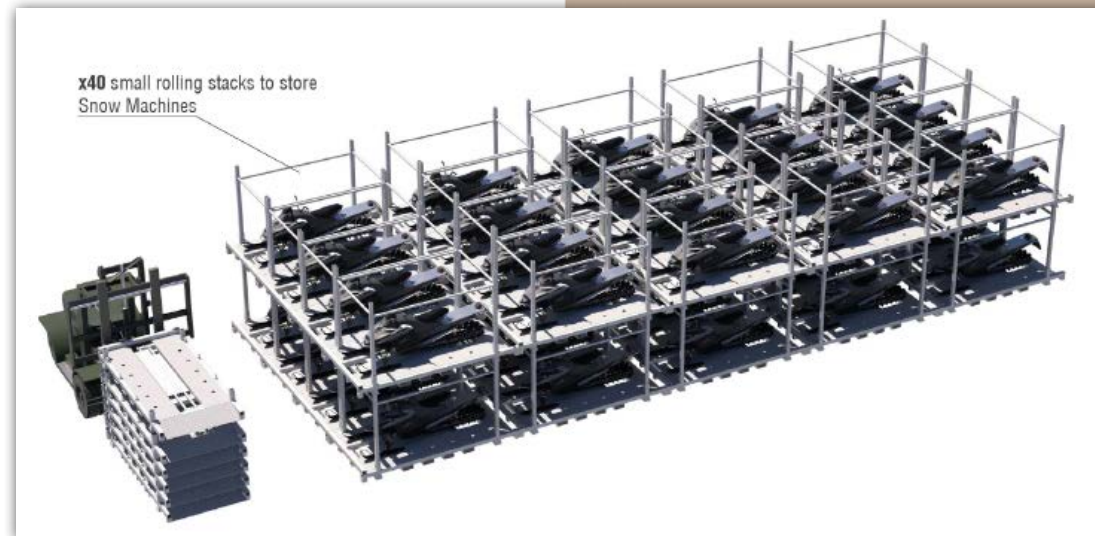

SIDE ACCESS FOR MAINTENANCE WHILST IN STACKED MODE

ASSEMBLED DESIGN FOR EFFICIENT SHIPPING

ALL UNITS CAPABLE OF STACKING 3 HIGH (SUBJECT TO LIFTING)



3K UDL = 3000 lbs **WEIGHT**

USABLE INTERNAL SPACE

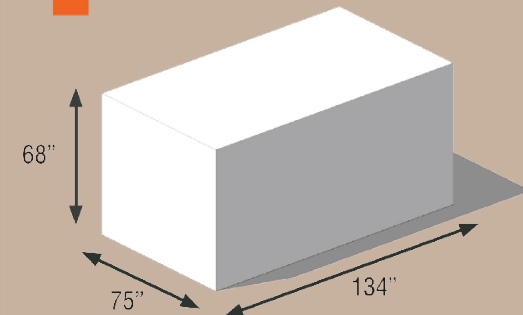

RS134.75.68-3K

BANAIR

© 2021 Elements Industrial Storage Ltd. All rights reserved.
No unauthorized copying or distribution without prior permission

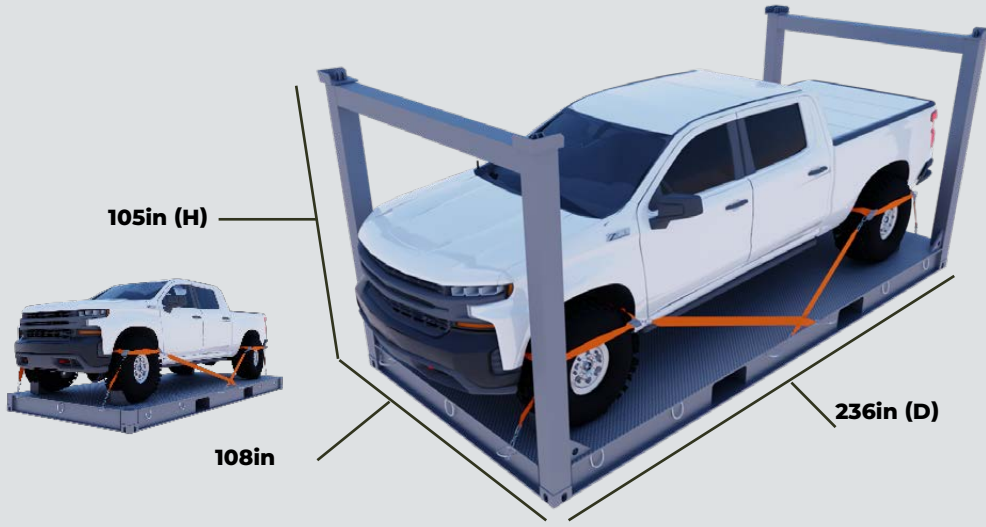

INTERNAL USEABLE
95.3in (W) X 236in (D) X 86.5in (H)

EXTERNAL (FLOOR TO STACKING LEVEL)
108in (W) X 236in (D) X 105in (H)



RS240.96.104-12K

BANAIR RollingStack Crate - Heavy Duty solution for large Rolling Stock, e.g. 1500 GAL water tanker, Ford F350, and also other bulky goods, sized to match 20ft shipping container. (12,000lbs)

RS240.96.104.12K

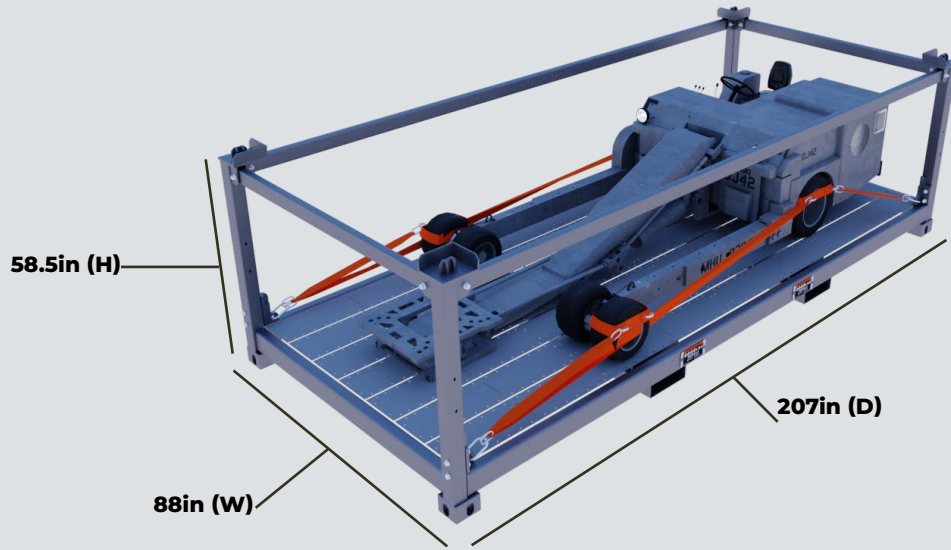

INTERNAL USEABLE
80in (W) X 207in (D) X 43.5in (H)

EXTERNAL (FLOOR TO STACKING LEVEL)
88in (W) X 207in (D) X 58.5in (H)

RS207.88.52-8K

BANAIR RollingStack Crate for MHU 83 C/D/E Bomblift (8,000lbs)
No overhang ends for Bomblift Family.

RS207.88.52.8K



MANUFACTURER

WWW.BAN-AIR.COM

SALES@BAN-AIR.COM

+44 121 401 1122 (EUROPE)

+1 919 753 8429 (USA)